



PGX -- Shure PGX Wireless

Quick Setup

SHURE®

PGX Wireless

Quick Start Guide

Mise en service rapide
Schnelles Einrichten

Preparación Rápida
Installazione rapida

Montagem Rápida
クイックセットアップ

快速设置指南
빠른 설정

Быстрая настройка
الأعداد السريع

1

connect receiver power cable

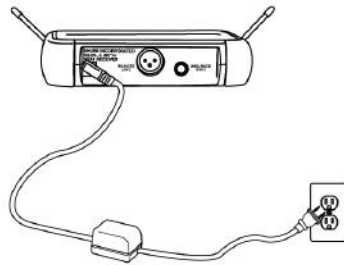

2

connect mixer or amplifier



3

2 x AA

add transmitter batteries

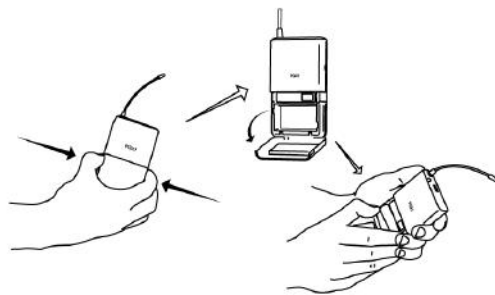

PGX1

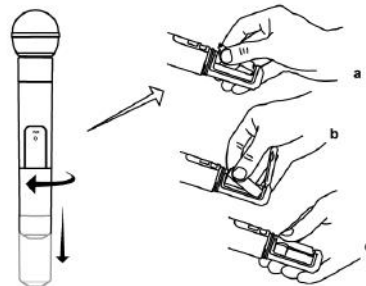

PGX2

4

power

scan for a clear channel and power up

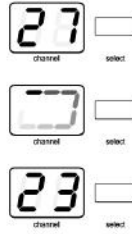
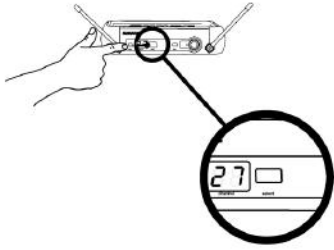

PGX1

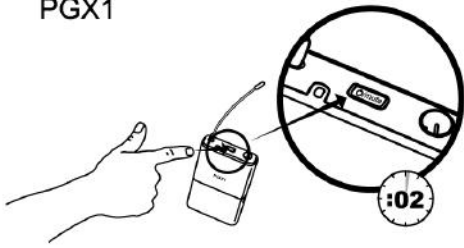

PGX2

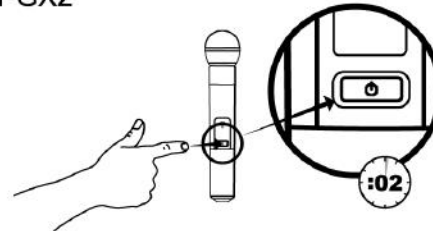

5

ready ?

automatic transmitter setup

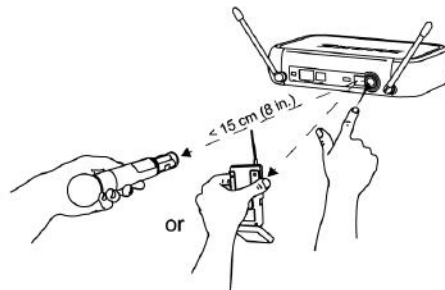
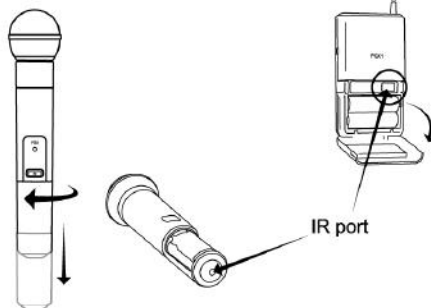

ready OK!

For detailed system information, see page 1 of the PGX user guide.

Pour plus de détails sur le système, voir la page 7 du guide d'utilisation du PGX.

Detaillierte Informationen zum System befinden sich auf Seite 13 der PGX-Bedienungsanleitung.

Para información más detallada del sistema, vea la página 19 de la guía del usuario del sistema PGX.

Per informazioni dettagliate sul sistema, consultare pagina 25 della guida all'uso del sistema PGX.

Para informações detalhadas sobre o sistema consulte a página 31 do guia do usuário do PGX.

システム情報の詳細は、PGX取扱説明書の43ページを参照してください。

关于详细的系统信息，请参考PGX用户手册第55页。

상세한 시스템 정보에 대해서는 PGX 사용자 안내서의 49 페이지를 참조하십시오.

Подробные сведения о системе см. на с. 37 руководства пользователя PGX.

للحصول على الإصدار العربي لهذا المستند، يرجى زيارة موقعنا <http://www.shure.com>.

System Components

All systems include:

- PGX4 receiver
- 2 AA batteries
- PS24 Power Supply
- User guide

Lavalier, Headworn, and Instrument systems include:

- PGX1 bodypack transmitter
- Microphone (choice of WL93, WL185, PG30 or Beta 98H/C™)

Vocalist systems include:

- Microphone Head (choice of PG58, SM58®, SM86, Beta 58A®)
- PGX2 handheld transmitter
- Microphone clip

Guitar systems include:

- PGX1 bodypack transmitter
- 1/4" to mini 4-pin guitar cable

PGX4 Receiver Features

Front Panel

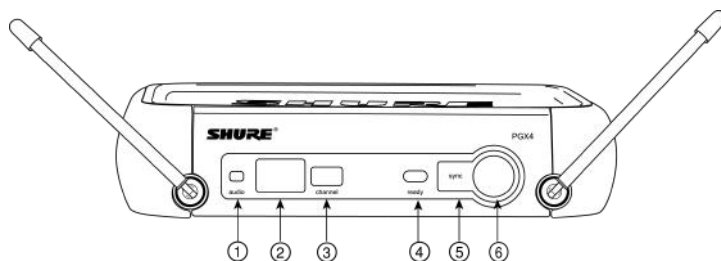

① audio LED

Indicates strength of incoming audio signal: green for normal, amber for strong and red for clipping.

② LED Screen

Displays group and channel setting. See “Single System Setup” for details.

③ channel button

Changes group and channel setting. See “Single System Setup” for details.

④ ready LED

Indicates system ready and receiving an RF signal from the transmitter.

⑤ Infrared (IR) port

Sends IR signal to transmitter for sync.

⑥ sync button

Press to synchronize transmitter with receiver group and channel settings.

Back Panel

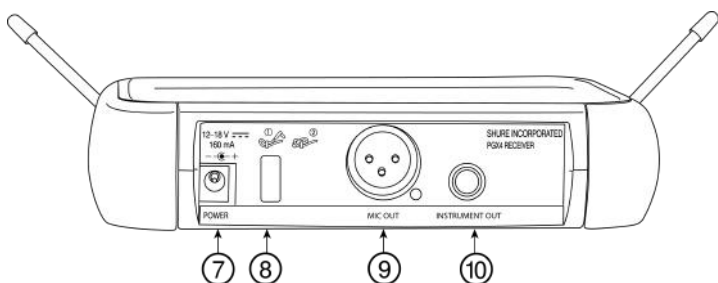

⑦ AC adapter jack

⑧ Adapter cord tie-off

⑨ XLR microphone output jack

⑩ 6.35 mm (1/4") instrument level output jack (unbalanced).

Transmitter Controls and Connectors

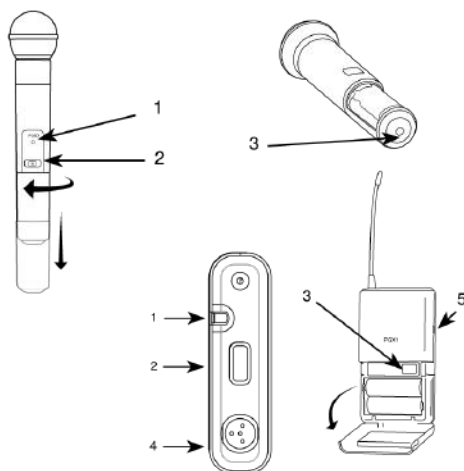

① Indicator LED Displays battery level, mute, and IR transmission status (see table).

② Power / Mute Switch Press to mute or unmute. Press and hold to power on or off.

③ Infrared (IR) port Receives infrared beam to synchronize frequencies. When using multiple systems, only one transmitter IR port should be exposed at a time.

④ 4-Pin Microphone Input Jack.

⑤ Audio Gain Adjustment.

Transmitter Indicator LED

Green	Ready
Flashing green	Controls Locked
Amber	Mute On
Flashing red	IR transmission in process
Glowing red	Battery power low
Pulsing Red on startup	Batteries dead (transmitter cannot be turned on until batteries are changed)
Pulsing Red after synchronization	Transmitter and receive incompatible; contact your Shure reseller

Changing Batteries



- Expected life for an Alkaline battery is approximately 8 hours.
- When the transmitter light glows red, the batteries should be changed immediately, as shown.

Wearing the Bodypack Transmitter

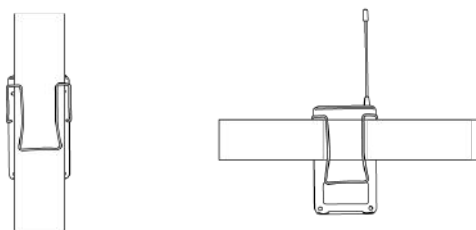

Clip the transmitter to a belt or slide a guitar strap through the transmitter clip as shown.

For best results, slide the transmitter until the belt is pressed against the base of the clip.

Adjusting Gain

PGX1

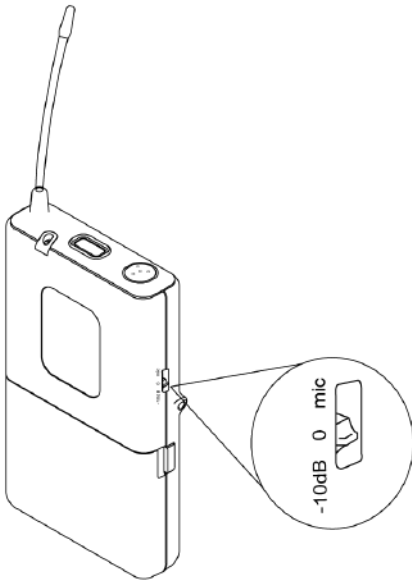

Three gain settings are available on the PGX1. Choose the appropriate setting for your instrument.

- mic: Microphone (higher amplification)
- 0: Guitar with passive pickups (medium amplification)
- -10: Guitar with active pickups (lower amplification)

If the receiver LED indicates the input volume is overloading the receiver, try switching the gain to a lower setting.

PGX2

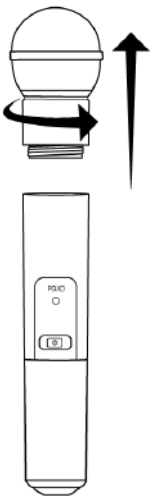

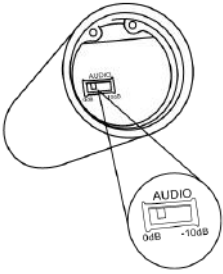

Access the gain adjustment switch by unscrewing the head of the microphone.

Two gain settings are available on the PGX2. Use the tip of a pen or a small screwdriver to move the switch.

- 0dB: For quiet to normal vocal performance.
- -10dB: Use only if audio is distorted due to high vocal levels.

Single System Setup

1 Scan

Use the scan feature on the receiver to find a clear channel.



a LED screen displays current channel



b press channel button to scan for a clear channel



c system scans for the channel with the least interference

2 Synchronize

Synchronize the transmitter to the receiver by aligning the infrared (IR) ports and pressing the sync button. Make sure the IR ports are closely aligned.

After a successful sync, the transmitter LED momentarily flashes red and the receiver ready light illuminates.

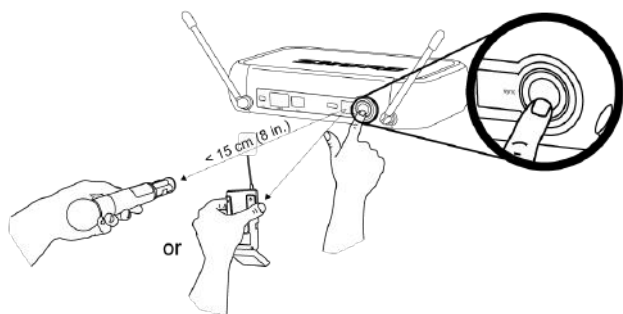

Multiple System Setup

Use the following steps to ensure the best performance when installing multiple wireless systems at the same location.

1. Turn all receivers on and all transmitters off.
Note: Turn on any other digital equipment that could cause interference during the performance so it will be detected during the frequency scans in the following steps.
2. Make sure the group number is the same for all receivers (see Manual Group Selection).
3. Perform a scan using the first receiver.
4. Turn on the first transmitter and sync it to the receiver.
5. Repeat for each system.
 - Important: After syncing each transmitter, leave it on so that scans from the other receivers will not select that channel.
 - Be sure only one transmitter IR port is exposed when synchronizing each system.

Manual Channel and Group Selection (receiver only)

Using the receiver to scan for a channel is the best way to find the best frequency for your system. However, for multiple system setup, you may need to manually set the group number.

1. Press and hold the **channel** button.
2. Hold the button until the channel or group display begins flashing.
3. Release and press the button again to advance the setting. At the desired channel or group number, wait for the flashing to stop. This activates the new setting.
4. Transfer the new frequency setting to the transmitter using the automatic sync function.

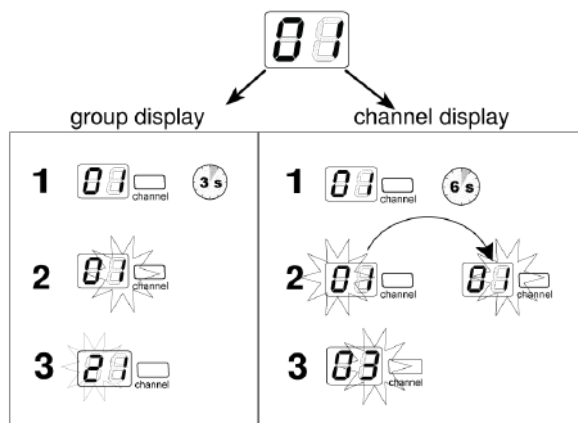

Locking and Unlocking Controls

Locking the system controls prevents accidental muting or channel adjustment during performances.

Transmitter

To lock the controls: With the transmitter off, hold the **power** button down until the green LED flashes (~5 seconds)

To unlock the controls: With the transmitter on, hold the **power** button down until the green LED flashes (~5 seconds)

Receiver

To lock the channel: Hold the **channel** button until the numbers flash (~10 seconds)

To unlock the channel: Hold the **channel** button until the numbers flash (~5 seconds)

Troubleshooting

Issue	Indicator Status	Solution
No sound or faint sound	Transmitter power light on, receiver LEDs on	<ul style="list-style-type: none"> • Perform automatic transmitter setup • Verify all sound system connections

Issue	Indicator Status	Solution
	Receiver LED off	<ul style="list-style-type: none">• Make sure AC adapter is securely plugged into electrical outlet• Make sure AC electrical outlet works and is supplying proper voltage
	Transmitter power light glowing or flashing red	<ul style="list-style-type: none">• Replace transmitter batteries• If indicator continues flashing red after batteries are replaced, the transmitter and receiver may belong to incompatible frequency bands. Contact your Shure reseller for assistance.

Issue	Indicator Status	Solution
	Transmitter power light off	<ul style="list-style-type: none">• Turn on transmitter• Make sure the +/- indicators on batteries match the transmitter terminals• Insert fresh batteries

Issue	Indicator Status	Solution
Distortion or unwanted noise bursts	N/A	<ul style="list-style-type: none"> • Remove nearby sources of RF interference (CD players, computers, digital effects, in-ear monitor systems, etc.) • ▸ Change receiver and transmitter to a different frequency • ▸ Reduce transmitter gain • ▸ Replace transmitter batteries • ▸ If using multiple systems, change the frequency of one of the active systems
Distortion increases gradually	Transmitter power light glowing or flashing red	Replace transmitter batteries

Issue	Indicator Status	Solution
Sound level different from cabled guitar or microphone or when using different guitars		Adjust transmitter gain as necessary
Cannot turn transmitter on	Transmitter light flashing red	Replace transmitter batteries

Specifications

Working Range

Line of Sight

100 m (300 ft) ^[1]

Audio Frequency Response

45–15000 Hz ^[2]

Total Harmonic Distortion

Ref. ±33 kHz deviation with 1 kHz tone

0.5%, typical

Dynamic Range

>100 dB, A-weighted

Operating Temperature Range

-18°C (0°F)—+50°C (122°F)[3]

Transmitter Audio Polarity

Positive pressure on microphone diaphragm (or positive voltage applied to tip of WA302 phone plug) produces positive voltage on pin 2 (with respect to pin 3 of low-impedance output) and the tip of the high impedance 1/4-inch output.

Note: Actual range depends on RF power setting, signal absorption, reflection, and interference.

Note: Dependent on microphone type

Note: Battery characteristics may limit this range.

Audio Input Level

gain position

mic	-10 dBV maximum	+10 dBV maximum	+20 dBV maximum
-----	-----------------	-----------------	-----------------

Gain Adjustment Range

30 dB

Input Impedance

1 M Ω

RF Output Power

10–30 mW ^[1]

Pin Assignments

TA4M connector

1	ground(cable shield)
2	+ 5 V Bias
3	audio
4	Tied through active load to ground (On instrument adapter cable, pin 4 floats)

Dimensions

108 mm x 64 mm x 19 mm (H x W x D)

Weight

81 g (3oz.), without batteries

Housing

Molded Polycarbonate Case

Power Requirements

2 "AA" size alkaline or rechargeable batteries

Battery Life

up to 8 hours (alkaline)

varies by region

Audio Input Level

-10 dB	+2 dBV maximum
0 dB	-8 dBV maximum

Gain Adjustment Range

10 dB

RF Output Power10–30 mW ^[1]**Dimensions**

254 mm x 51 mm dia. (10 x 12 in.)

Weight

81 g (10.2 oz.), without batteries

Housing

Molded PC/ABS handle and battery cup

Power Requirements

2 "AA" size alkaline or rechargeable batteries

Battery Life

up to 8 hours (alkaline)

varies by region

Frequency Range and Transmitter Output Level

Band	Range	Output Power
H6	524–542 MHz	30 mW
J6	572.250–590.875 MHz	30 mW
K5E	606–630 MHz	10 mW
L5	644–662 MHz	30 mW
P6	702.200–719 MHz	30 mW
R1	800–820 MHz	20 mW

Band	Range	Output Power
T1	846–865 MHz	10 mW
Q8	740–752 MHz	10 mW
JB	806–810 MHz	10 mW
R14	794–806 MHz	20 mW
X5	925–932 MHz	10 mW
G4	470.125–493.825 MHz	30 mW
G8	494.200–509.825 MHz	30 mW
Q24	736–754 MHz	30 mW

This Radio equipment is intended for use in musical professional entertainment and similar applications. This Radio apparatus may be capable of operating on some frequencies not authorized in your region. Please contact your national authority to obtain information on authorized frequencies and RF power levels for wireless microphone products.

Frequency Range and Transmitter Output Power

Band	Frequency Range (MHz)	Power (mW RMS)* (Lo/Nm/Hi)
G50	470 to 534	1 / 10
G51	470 to 534	1 / 10
G52	479 to 534	1 / 10
G62	510 to 530	1 / 10
H50	534 to 598	1 / 10
H51	534 to 598	1 / 10
H52	534 to 565	1 / 10
H53	534 to 598	1 / 10
J50	572 to 636	1 / 10

Band	Frequency Range (MHz)	Power (mW RMS)* (Lo/Nm/Hi)
J51	572 to 636	1 / 10
JB	806 to 810	1 / 10
K51	606 to 670	1 / 10
K52	606 to 670	1 / 10
L50	632 to 696	1 / 10
L51	632 to 696	1 / 10
L52	632 to 694	1 / 10
L53	632 to 714	1 / 10
P51	710 to 782	1 / 10
P52	710 to 782	1 / 10
Q51	794 to 806	1 / 10
S50	(823 to 832) (863 to 865)	1 / 10
V50	174 to 216	1 / 10
V51	174 to 216	1 / 10
X51	925 -937.5	1 / 10
X52	902 to 928 (All America's except Brazil)	1 / 10
X53	902 to 907.500, 915 to 928 (Brazil)	1 / 10
X54	915 to 928 (Australia)	1 / 10
Z17	1492 to 1525	1 / 10
Z18	1785 to 1805	1 / 10
Z19	1785 to 1800	1 / 10
Z20	1790 to 1805	1 / 10

Note: Frequency bands might not be available for sale or authorized for use in all countries or regions.

PGX1, PGX2, PGX4

This Class B digital apparatus complies with Canadian ICES-003. Cet appareil numérique de la classe B est conforme à la norme NMB-003 du Canada.

Meets requirements of EMC standards EN 300 328, EN 300 422 Parts 1 and 2, and EN 301 489 Parts 1 and 9.

Meets essential requirements of European R&TTE Directive 99/5/EC, eligible to bear the CE mark.

PGX1, PGX2

Certified under FCC Part 74. (**FCC ID:** DD4PGX1A, DD4PGX2A, DD4SLX1, DD4SLX2). Certified by IC in Canada under RSS-123 and RSS-102. (**IC:** 616A-SLX1, 616A-SLX2).

PGX4

Approved under the Declaration of Conformity (DoC) provision of FCC Part 15. Certified in Canada by IC to RSS-123. (**IC:** 616A-PGX4A, 616A-PGX4B, 616A-PGX4C, 616A-PGX4D).

The CE Declaration of Conformity can be obtained from Shure Incorporated or any of its European representatives. For contact information please visit www.shure.com

The CE Declaration of Conformity can be obtained from: www.shure.com/europe/compliance

Authorized European representative:

Shure Europe GmbH

Headquarters Europe, Middle East & Africa

Department: EMEA Approval

Jakob-Dieffenbacher-Str. 12

75031 Eppingen, Germany

Phone: +49-7262-92 49 0

Fax: +49-7262-92 49 11 4

Email: info@shure.de

LICENSING INFORMATION

Licensing: A ministerial license to operate this equipment may be required in certain areas. Consult your national authority for possible requirements. Changes or modifications not expressly approved by Shure Incorporated could void your authority to operate the equipment. Licensing of Shure wireless microphone equipment is the user's responsibility, and licensability depends on the user's classification and application, and on the selected frequency. Shure strongly urges the user to contact the appropriate telecommunications authority concerning proper licensing, and before choosing and ordering frequencies.

Information to the user

This equipment has been tested and found to comply with the limits for a Class B digital device, pursuant to Part 15 of the FCC Rules. These limits are designed to provide reasonable protection against harmful interference in a residential installation. This equipment generates uses and can radiate radio frequency energy and, if not installed and used in accordance with the instructions, may cause harmful interference to radio communications. However, there is no guarantee that interference will not occur in a particular installation. If this equipment does cause harmful interference to radio or television reception, which can be determined by turning the equipment off and on, the user is encouraged to try to correct the interference by one or more of the following measures:

- Reorient or relocate the receiving antenna.
- Increase the separation between the equipment and the receiver.
- Connect the equipment to an outlet on a circuit different from that to which the receiver is connected.
- Consult the dealer or an experienced radio/TV technician for help.

Note: EMC conformance testing is based on the use of supplied and recommended cable types. The use of other cable types may degrade EMC performance.

Changes or modifications not expressly approved by the manufacturer could void the user's authority to operate the equipment.

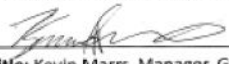
<p style="text-align: center;">PERU DECLARATION OF CONFORMITY</p> <p style="text-align: center;">Shure Incorporated 5800 W. Touhy Avenue Niles, Illinois 60714-4608, U.S.A. (847) 600-2000</p> <p>Shure Incorporated declares that the following product</p> <p>Model: <u>PGX1-H6 (524-542MHz) PGX1-J6 (572-590MHz) PGX1-L5 (644-662MHz)</u></p> <p>Description: <u>UHF FM Wireless Microphone Transmitter</u></p> <p>Has been tested and found to comply with the limits set in Peru wireless regulatory standard RM N° 204-2009-MTC/03. It's effective radiated power (ERP) has been measured to be less than 10 mW, as measured in accordance with ETSI standard EN 300 422.</p> <p>Signed <u></u> Date: <u>August 24, 2009</u></p> <p>Name, Title: <u>Kevin Marrs, Manager, Global Compliance, Shure Incorporated</u></p>

PERU DECLARATION OF CONFORMITY

Shure Incorporated
5800 W. Touhy Avenue
Niles, Illinois 60714-4608, U.S.A.
(847) 600-2000

Shure Incorporated declares that the following product

Model: PGX2-H6 (524-542MHz) PGX2-J6 (572-590MHz) PGX2-L5 (644-662MHz)

Description: UHF FM Wireless Microphone Transmitter

Has been tested and found to comply with the limits set in Peru wireless regulatory standard **RM N° 204-2009-MTC/03**. It's effective radiated power (ERP) has been measured to be less than 10 mW, as measured in accordance with ETSI standard EN 300 422.

Signed  Date: August 24, 2009

Name, Title: Kevin Marrs, Manager, Global Compliance, Shure Incorporated